

Product Summary

$V_{(BR)DSS}$	$R_{DS(on)TYP}$	I_D
68V	7.0mΩ@10V	80A

Feature

- High cell density trench N-ch MOSFETs
- Super low gate charge
- Advanced high cell density Trench technology

Application

- High side switch in POL DC/DC converter
- Secondary side synchronous rectifier

Equivalent circuit

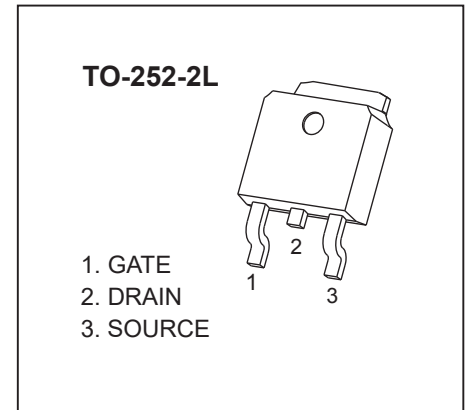
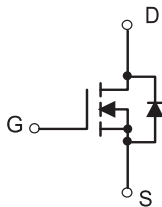

ABSOLUTE MAXIMUM RATINGS ($T_C=25^\circ\text{C}$ unless otherwise noted)

Parameter	Symbol	Value	Unit	
Drain-Source Voltage	V_{DS}	68	V	
Gate-Source Voltage	V_{GS}	±20	V	
Continuous Drain Current	$I_D^{(1)}$	$T_C=25^\circ\text{C}$	80	A
		$T_C=70^\circ\text{C}$	64	A
Pulsed Drain Current	$I_{DM}^{(1), (2)}$	320	A	
Single Pulsed Avalanche Energy	E_{AS}^*	485	mJ	
Power Dissipation	P_D	1.25	W	
Thermal Resistance from Junction to Ambient	$R_{\theta JA}$	100	$^\circ\text{C/W}$	
Junction Temperature	T_J	150	$^\circ\text{C}$	
Storage Temperature	T_{STG}	-55~ +150	$^\circ\text{C}$	

* E_{AS} Test Condition: $L = 0.95\text{ mH}$, $I_{AS} = 32\text{ A}$, $V_{DD} = 10\text{ V}$, $R_G = 25\ \Omega$, Starting $T_J = 25^\circ\text{C}$.

MOSFET ELECTRICAL CHARACTERISTICS (T_J=25°C unless otherwise noted)

Parameter	Symbol	Test Condition	Min	Type	Max	Unit
Static Characteristics						
Drain-source breakdown voltage	V _{(BR)DSS}	V _{GS} = 0V, I _D =250μA	68			V
Zero gate voltage drain current	I _{DSS}	V _{DS} =68V, V _{GS} = 0V			1	μA
Gate-body leakage current	I _{GSS}	V _{GS} =±20V, V _{DS} = 0V			±100	nA
Gate threshold voltage	V _{GS(th)} ⁽⁴⁾	V _{DS} =V _{GS} , I _D =250μA	2.0	3.0	4.0	V
Drain-source on-resistance	R _{DS(on)} ⁽⁴⁾	V _{GS} =10V, I _D =40A		7.0	8.5	mΩ
Forward tranconductance	g _{FS} ⁽⁴⁾	V _{DS} =10V, I _D =40A		34		S
Dynamic characteristics ⁽⁵⁾						
Input capacitance	C _{iss}	V _{DS} =25V, V _{GS} =0V, f =1MHz		3899		pF
Output capacitance	C _{oss}			320		
Reverse transfer capacitance	C _{rss}			303		
Switching Characteristics ⁽⁵⁾						
Total gate charge	Q _g	V _{DS} =35V, V _{GS} =10V, I _D =40A		75		nC
Gate-source charge	Q _{gs}			26		
Gate-drain charge	Q _{gd}			20		
Turn-on delay time	t _{d(on)}	V _{DD} =35V, V _{GS} =10V, R _G =4.7Ω, I _D =40A		20		ns
Turn-on rise time	t _r			52		
Turn-off delay time	t _{d(off)}			49		
Turn-off fall time	t _f			23		
Diode Characteristics						
Continuous Source Current	I _S	V _G =V _D =0V , Force Current			80	A
Pulsed Source Current	I _{SM}				320	
Diode Forward Voltage	V _{SD} ⁽⁴⁾	V _{GS} =0V , I _S =40A , T _J =25°C			1.2	V

Notes:

- 1.The data tested by surface mounted on a 1 inch² FR-4 board with 2OZ copper
- 2.Pulse Test:Pulse Width < 10us, Duty Cycle < 0.5%.
- 3.The power dissipation is limited by 150°C junction temperature
- 4.Pulse Test : Pulse width≤300μs, duty cycle≤2%.
- 5.Guaranteed by design, not subject to production testing.
- 6.The data is theoretically the same as I_D, in real applications , should be limited by total power dissipation.

Typical Electrical and Thermal Characteristics

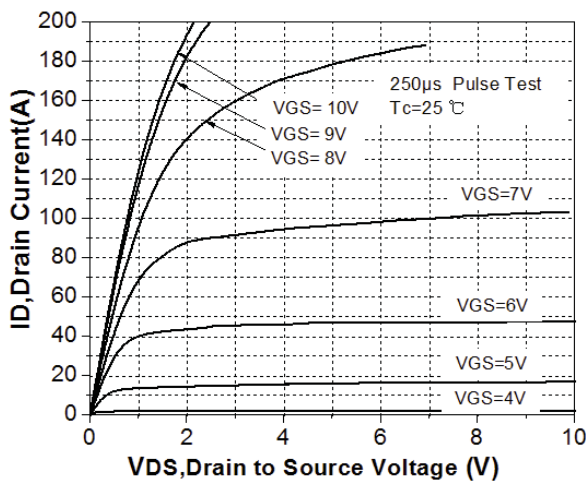

Figure 1. On-Region Characteristics

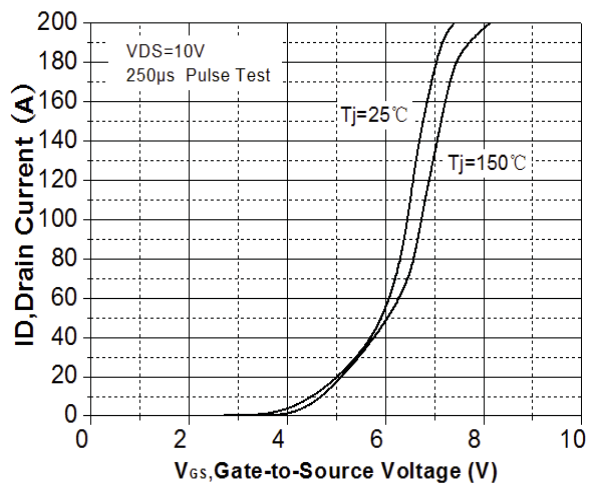

Figure 2. Transfer Characteristics

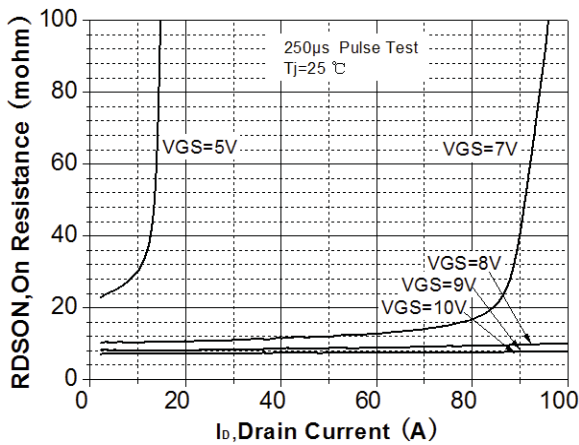

Figure 3. On-Resistance Variation vs Drain Current and Gate Voltage

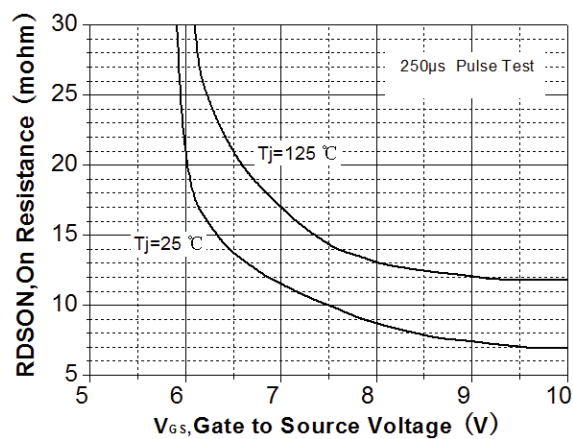

Figure 4. On-Resistance vs. Gate to Source Voltage

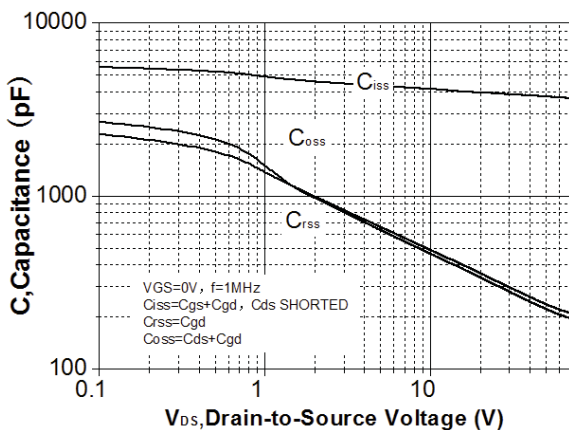

Figure 5. Capacitance Characteristics

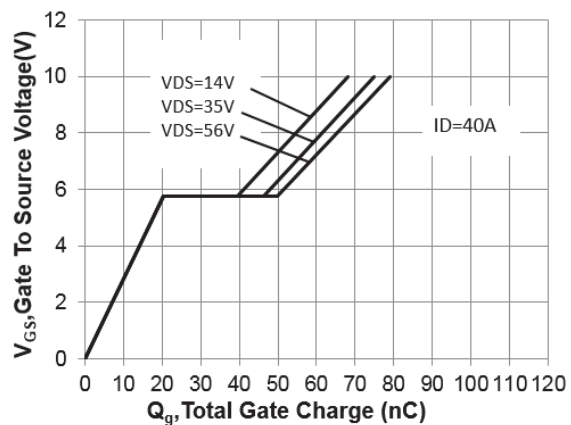

Figure 6. Gate Charge Characteristics

Typical Electrical and Thermal Characteristics

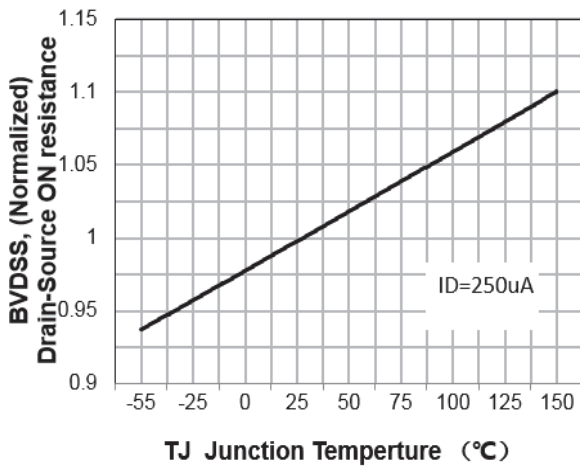

Figure 7. Breakdown Voltage Variation vs Temperature

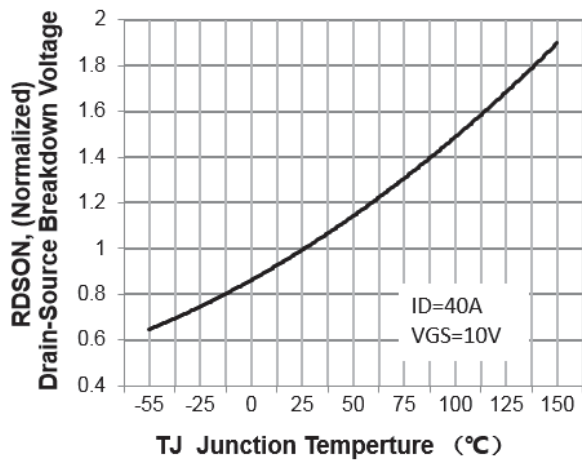

Figure 8. On-Resistance Variation vs Temperature

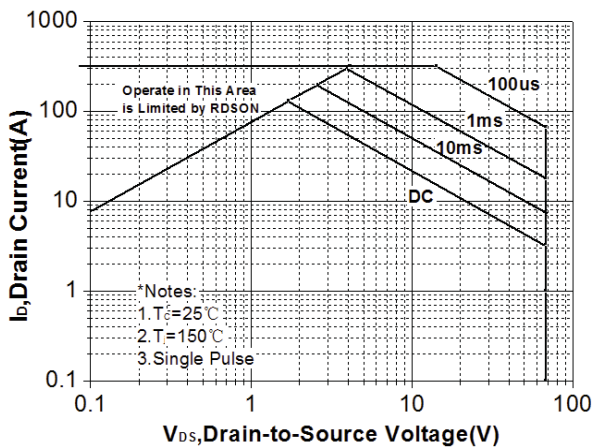

Figure 9. Maximum Safe Operating Area

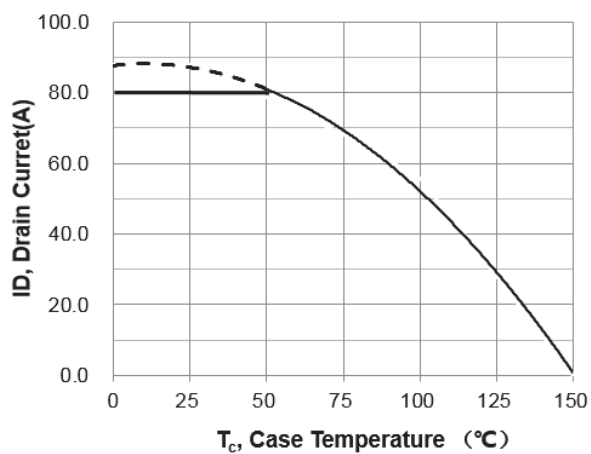

Figure 10. Maximum Drain Current vs Case Temperature

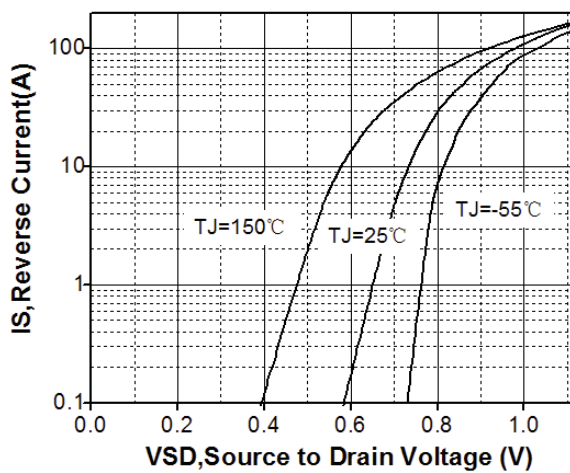

Figure 11. Body Diode Forward Voltage Vs Reverse Drain Current

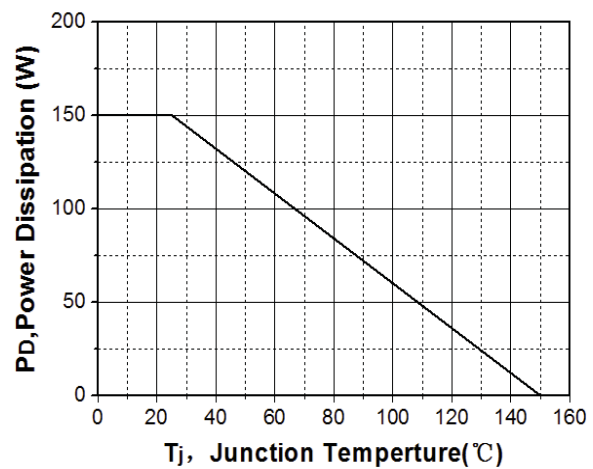

Figure 12. Power Dissipation vs Junction Temperature

Typical Electrical and Thermal Characteristics

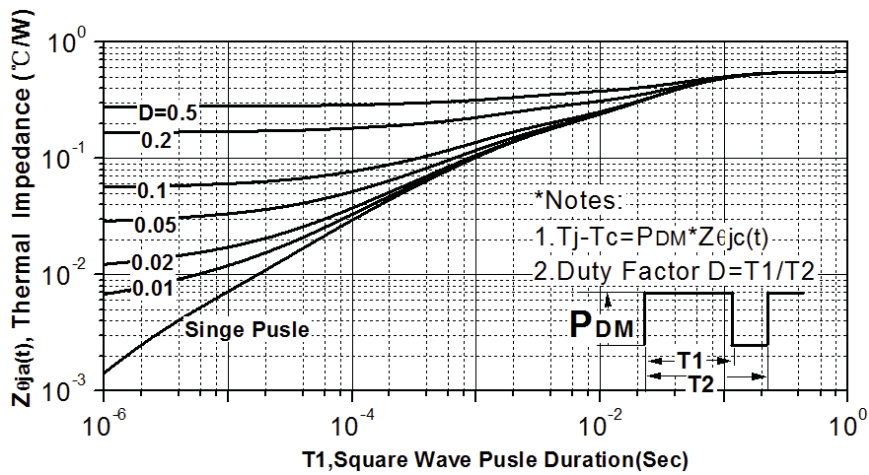

Figure 13. Transient Thermal Response Curve

Test Circuit & Waveform

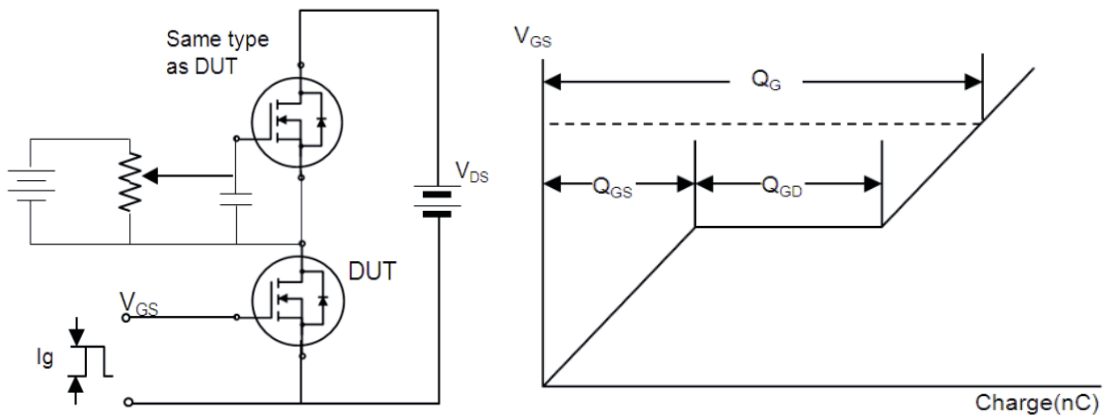

Figure 14. Gate charge test circuit & waveform

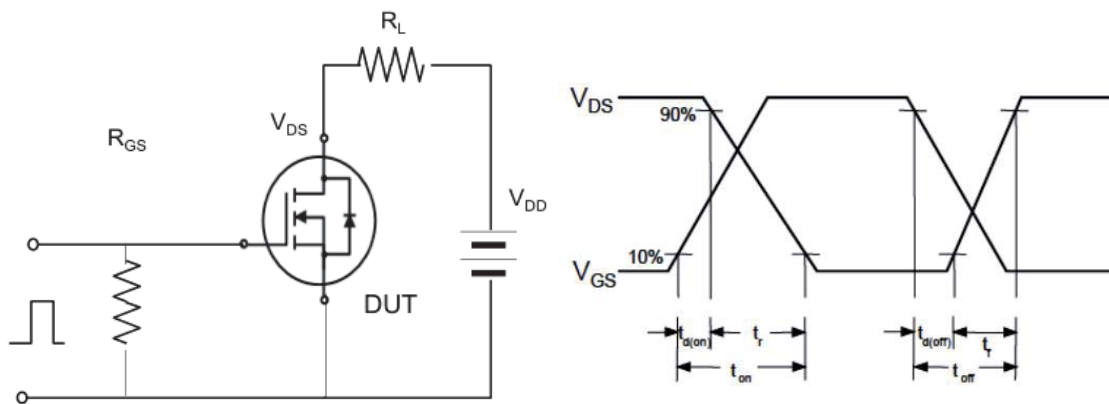
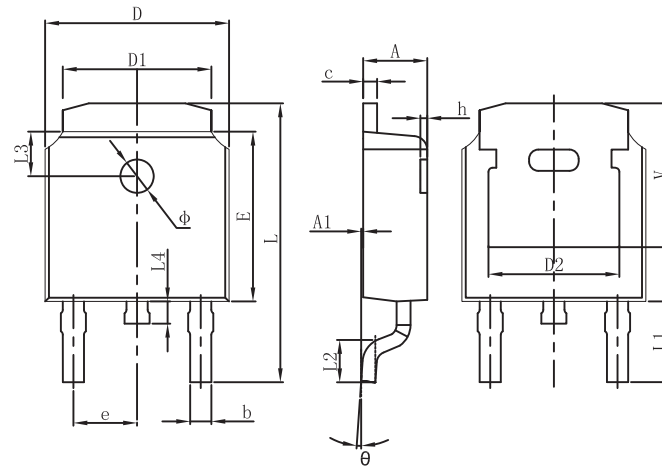

Figure 15. Switching time test circuit & waveform

TO-252-2L Package Information



Symbol	Dimensions In Millimeters		Dimensions In Inches	
	Min.	Max.	Min.	Max.
A	2.200	2.400	0.087	0.094
A1	0.000	0.127	0.000	0.005
b	0.635	0.770	0.025	0.030
c	0.460	0.580	0.018	0.023
D	6.500	6.700	0.256	0.264
D1	5.100	5.460	0.201	0.215
D2	4.830 REF.		0.190 REF.	
E	6.000	6.200	0.236	0.244
e	2.186	2.386	0.086	0.094
L	9.712	10.312	0.382	0.406
L1	2.900 REF.		0.114 REF.	
L2	1.400	1.700	0.055	0.067
L3	1.600 REF.		0.063 REF.	
L4	0.600	1.000	0.024	0.039
φ	1.100	1.300	0.043	0.051
θ	0°	8°	0°	8°
h	0.000	0.300	0.000	0.012
V	5.250 REF.		0.207 REF.	