



### Product Summary

$V_{(BR)DSS}$	$R_{DS(on)TYP}$	$I_D$
600V	3.6Ω@10V	2A

### Feature

- Low  $R_{DS(on)}$
- Low FOM
- Extremely low switching loss
- Good stability and uniformity

### Application

- Consumer electronics power supply
- LED Lighting
- Standby Power
- Charger

TO-220-3L-F



Schematic diagram

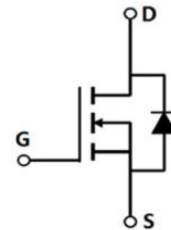

### MARKING:

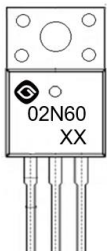

02N60 = Device Code  
XX = Date Code

### ABSOLUTE MAXIMUM RATINGS ( $T_A = 25^\circ\text{C}$ unless otherwise noted)

Parameter	Symbol	Value	Unit
Drain - Source Voltage	$V_{DS}$	600	V
Gate - Source Voltage	$V_{GS}$	±30	V
Continuous Drain Current <sup>1,6</sup>	$I_D$	2	A
Pulsed Drain Current <sup>2</sup>	$I_{DM}$	9	A
Single Pulsed Avalanche Current <sup>3</sup>	$I_{AS}$	5.8	A
Single Pulsed Avalanche Energy <sup>3</sup>	$E_{AS}$	8.4	mJ
Power Dissipation <sup>5,6</sup>	$P_D$	25	W
Thermal Resistance from Junction to Ambient <sup>6</sup>	$R_{\theta JC}$	5	$^\circ\text{C}/\text{W}$
Junction Temperature	$T_J$	150	$^\circ\text{C}$
Storage Temperature	$T_{STG}$	-55~ +150	$^\circ\text{C}$

## MOSFET ELECTRICAL CHARACTERISTICS ( $T_J = 25^\circ\text{C}$ unless otherwise noted)

Parameter	Symbol	Test Condition	Min	Type	Max	Unit
<b>Off Characteristics</b>						
Drain - Source Breakdown Voltage	$V_{(BR)DSS}$	$V_{GS} = 0V, I_D = 250\mu A$	600			V
Zero Gate Voltage Drain Current	$I_{DSS}$	$V_{DS} = 600V, V_{GS} = 0V$			1	$\mu A$
Gate - Body Leakage Current	$I_{GSS}$	$V_{GS} = \pm 30V, V_{DS} = 0V$			$\pm 100$	nA
<b>On Characteristics<sup>4</sup></b>						
Gate Threshold Voltage	$V_{GS(th)}$	$V_{DS} = V_{GS}, I_D = 250\mu A$	2.0	3.2	4.0	V
Drain-source On-resistance	$R_{DS(on)}$	$V_{GS} = 10V, I_D = 1A$		3.6	5.0	$\Omega$
<b>Dynamic Characteristics</b>						
Input Capacitance	$C_{iss}$	$V_{DS} = 50V, V_{GS} = 0V, f = 1MHz$		337		pF
Output Capacitance	$C_{oss}$			20.5		
Reverse Transfer Capacitance	$C_{rss}$			0.4		
Gate Resistance	$R_g$	$V_{DS} = 0V, V_{GS} = 0V, f = 1MHz$		3.3		$\Omega$
<b>Switching Characteristics</b>						
Total Gate Charge	$Q_g$	$V_{DS} = 300V, V_{GS} = 10V, I_D = 1A$		13.7		nC
Gate-source Charge	$Q_{gs}$			1.7		
Gate-drain Charge	$Q_{gd}$			3.8		
Turn-on Delay Time	$t_{d(on)}$	$V_{DD} = 300V, V_{GS} = 10V, I_D = 2A, R_G = 3\Omega$		12		ns
Turn-on Rise Time	$t_r$			21		
Turn-off Delay Time	$t_{d(off)}$			30		
Turn-off Fall Time	$t_f$			24		
<b>Source - Drain Diode Characteristics</b>						
Diode Forward Voltage <sup>4</sup>	$V_{SD}$	$V_{GS} = 0V, I_S = 2A$			1.2	V

### Notes :

1. The maximum current rating is limited by package.
2. Pulse Test : Pulse Width  $\leq 10\mu s$ , duty cycle  $\leq 1\%$ .
3. EAS condition:  $V_{DD} = 100V, V_{GS} = 10V, L = 0.5mH, R_G = 25\Omega$  Starting  $T_J = 25^\circ\text{C}$ .
4. Pulse Test : Pulse Width  $\leq 300\mu s$ , duty cycle  $\leq 2\%$ .
5. The power dissipation  $P_D$  is limited by  $T_{J(MAX)} = 150^\circ\text{C}$ .
6. Device mounted on  $1in^2$  FR-4 board with 2oz. Copper, in a still air environment with  $T_A = 25^\circ\text{C}$ .

## Typical Characteristics

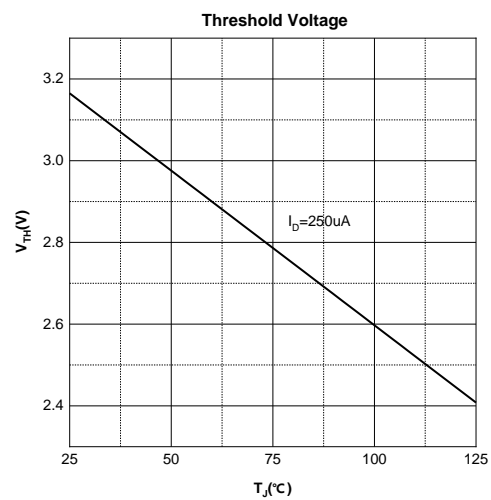
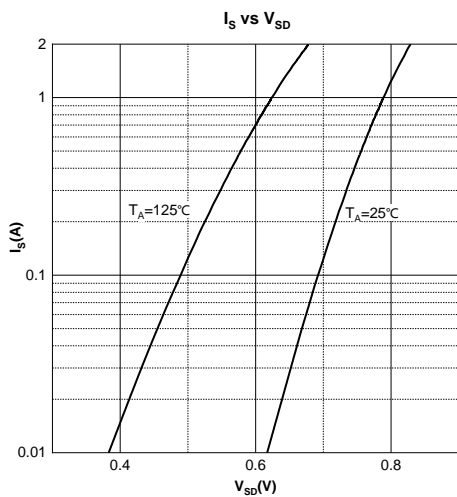
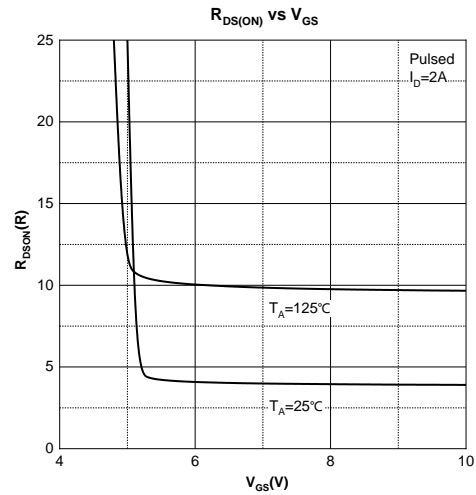
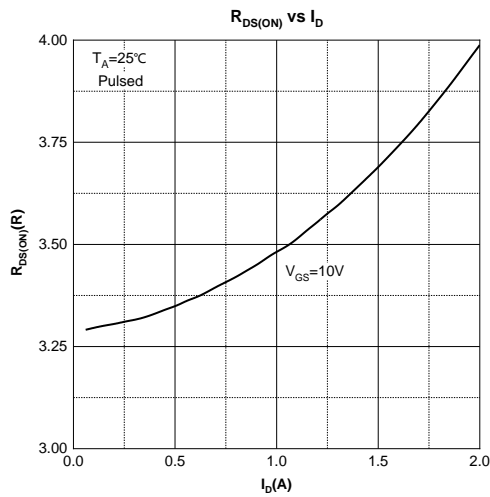
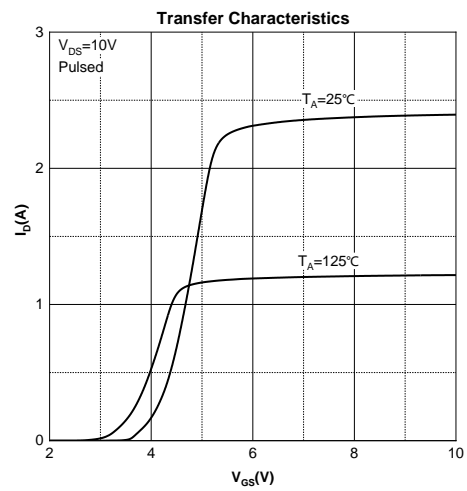
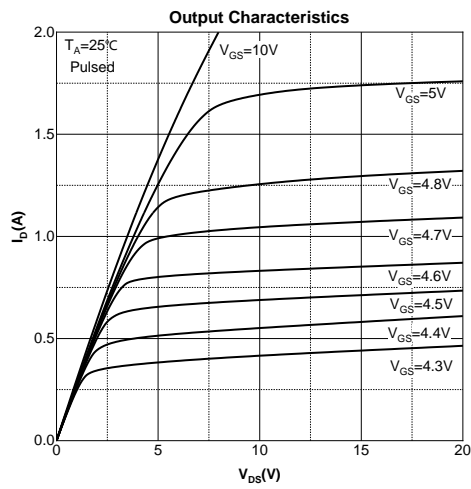

## TO-220-3L-F Package Information

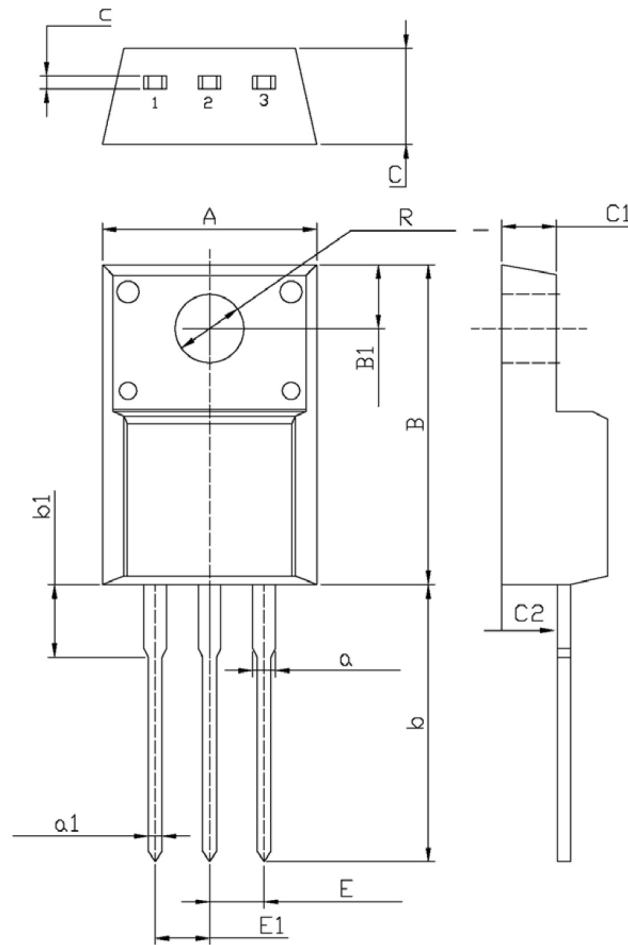

Symbol	Dimensions In Millimeters		Dimensions In Inches	
	Min.	Max.	Min.	Max.
C	4.500	4.900	0.177	0.193
c	0.400	0.600	0.016	0.024
A	9.960	10.360	0.392	0.408
B	15.670	16.070	0.617	0.633
B1	3.300	3.500	0.130	0.138
R	3.080	3.280	0.121	0.129
b	12.480	13.480	0.491	0.531
b1	2.900	3.900	0.114	0.154
a	1.080	1.480	0.043	0.058
a1	0.700	0.900	0.028	0.035
E	2.340	2.740	0.092	0.108
E1	2.340	2.740	0.092	0.108
C1	2.340	2.740	0.092	0.108
C2	2.560	2.960	0.101	0.117