



#### Product Summary

$V_{(BR)DSS}$	$R_{DS(on)TYP}$	$I_D$
-40V	63mΩ@-10V	-10A
	98mΩ@-4.5V	

#### Feature

- TrenchFET Power MOSFET
- Exceptional on-resistance and maximum DC current capability

#### Application

- DC/DC Converter
- Load Switch for Portable Devices
- Battery Switch

#### MARKING:



#### TO-252-2L

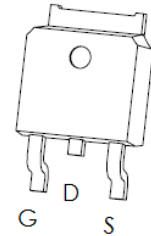

Schematic diagram

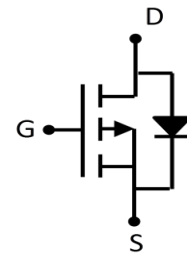

#### ABSOLUTE MAXIMUM RATINGS ( $T_a=25^{\circ}\text{C}$ unless otherwise noted)

Parameter	Symbol	Value	Unit
Drain-Source Voltage	$V_{DS}$	-40	V
Gate-Source Voltage	$V_{GS}$	±20	V
Continuous Drain Current	$I_D$	-10	A
Pulsed Drain Current	$I_{DM}$	-40	A
Power Dissipation	$P_D$	1.25	W
Thermal Resistance from Junction to Ambient	$R_{\theta JA}$	100	$^{\circ}\text{C/W}$
Junction Temperature	$T_J$	150	$^{\circ}\text{C}$
Storage Temperature	$T_{STG}$	-55~ +150	$^{\circ}\text{C}$

## MOSFET ELECTRICAL CHARACTERISTICS ( $T_a=25^{\circ}\text{C}$ unless otherwise noted)

Parameter	Symbol	Test Condition	Min	Type	Max	Unit
<b>Static Characteristics</b>						
Drain-source breakdown voltage	$V_{(BR)DSS}$	$V_{GS} = 0V, I_D = -250\mu A$	-40			V
Zero gate voltage drain current	$I_{DSS}$	$V_{DS} = -40V, V_{GS} = 0V$			-1	$\mu A$
Gate-body leakage current	$I_{GSS}$	$V_{GS} = \pm 20V, V_{DS} = 0V$			100	nA
Gate threshold voltage <sup>(1)</sup>	$V_{GS(th)}$	$V_{DS} = V_{GS}, I_D = -250\mu A$	-1.0	-2.1	-3.0	V
Drain-source on-resistance <sup>(1)</sup>	$R_{DS(on)}$	$V_{GS} = -10V, I_D = -10A$		63	85	m $\Omega$
		$V_{GS} = -4.5V, I_D = -8A$		98	126	
Forward transconductance	$g_{FS}$	$V_{DS} = -5V, I_D = -10A$	7			S
<b>Dynamic characteristics<sup>(2)</sup></b>						
Input Capacitance	$C_{iss}$	$V_{DS} = -20V, V_{GS} = 0V, f = 1MHz$		445		pF
Output Capacitance	$C_{oss}$			19		
Reverse Transfer Capacitance	$C_{rss}$			15		
Total Gate Charge	$Q_g$	$V_{DS} = -20V, I_D = -10A, V_{GS} = -10V$		14		nC
Gate-Source Charge	$Q_{gs}$			2.9		
Gate-Drain Charge	$Q_{gd}$			3.8		
<b>Switching characteristics<sup>(2)</sup></b>						
Turn-on delay time	$t_{d(on)}$	$V_{DD} = -20V, R_L = 2\Omega$ $V_{GS} = -10V, R_{GEN} = 3\Omega$		8		ns
Turn-on rise time	$t_r$			9		
Turn-off delay time	$t_{d(off)}$			28		
Turn-off fall time	$t_f$			10		
<b>Source-Drain Diode characteristics</b>						
Diode Forward voltage <sup>(1)</sup>	$V_{DS}$	$V_{GS} = 0V, I_S = -10A$		-0.87	-1.2	V

### Notes:

1. Pulse test; pulse width  $\leq 300\mu s$ , duty cycle  $\leq 2\%$ .
2. Guaranteed by design, not subject to production testing.

**Typical Electrical and Thermal Characteristics**

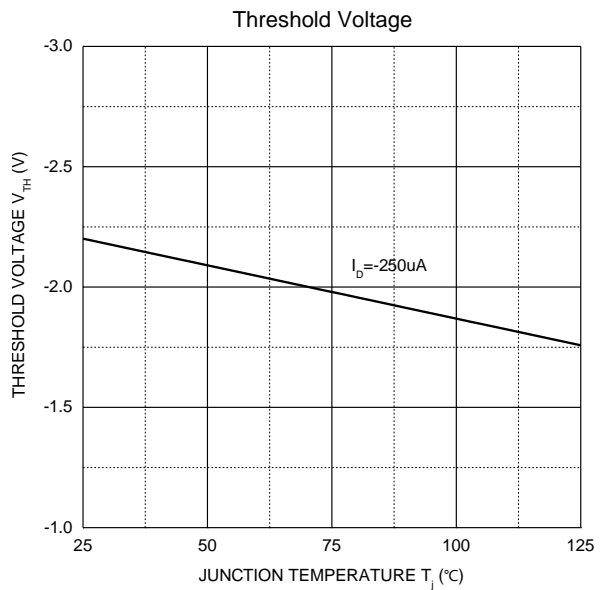
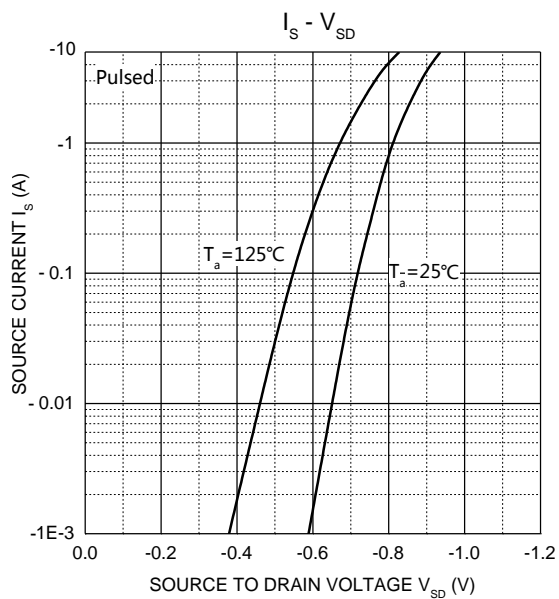
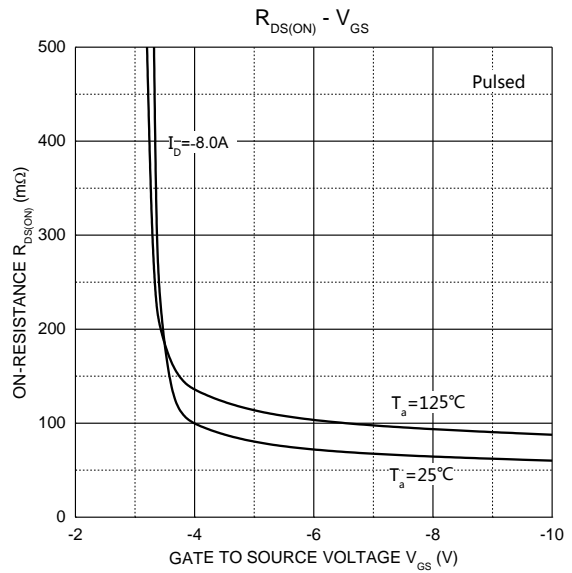
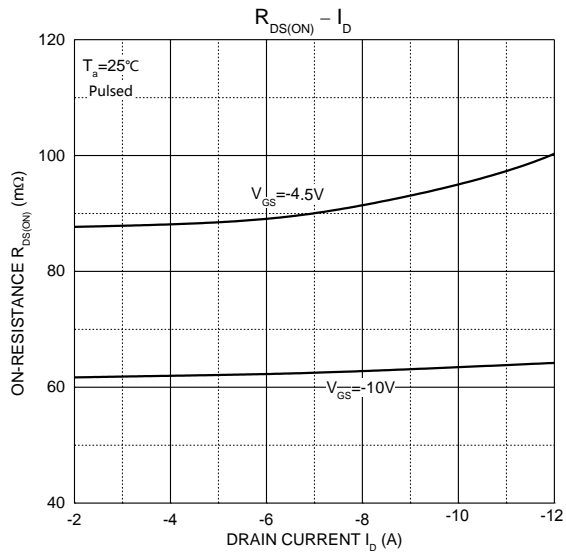
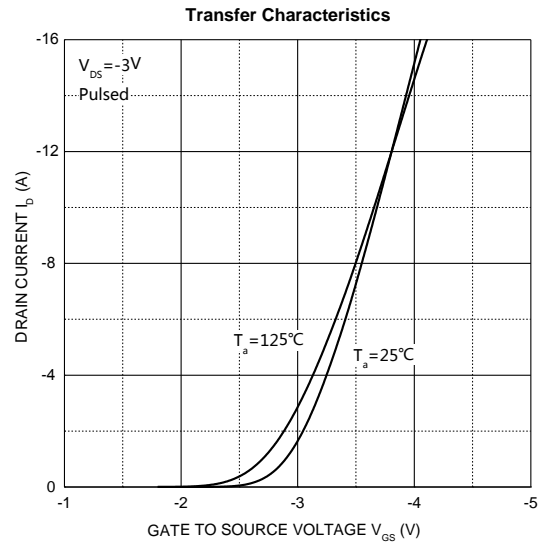
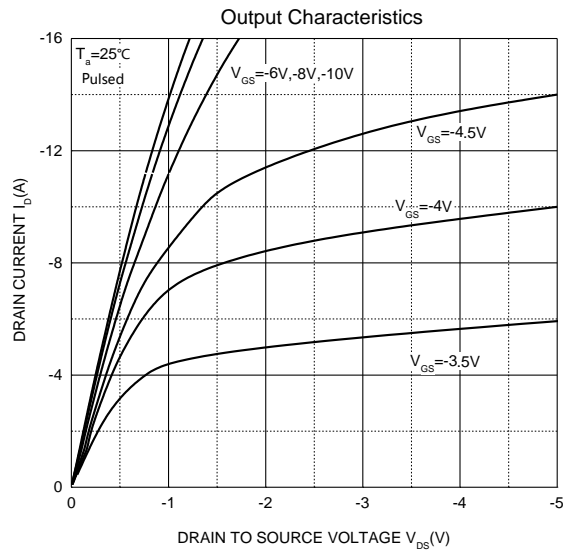

## TO-252-2L Package Information

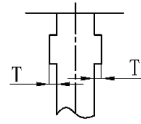
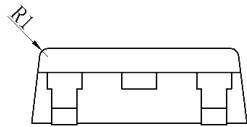
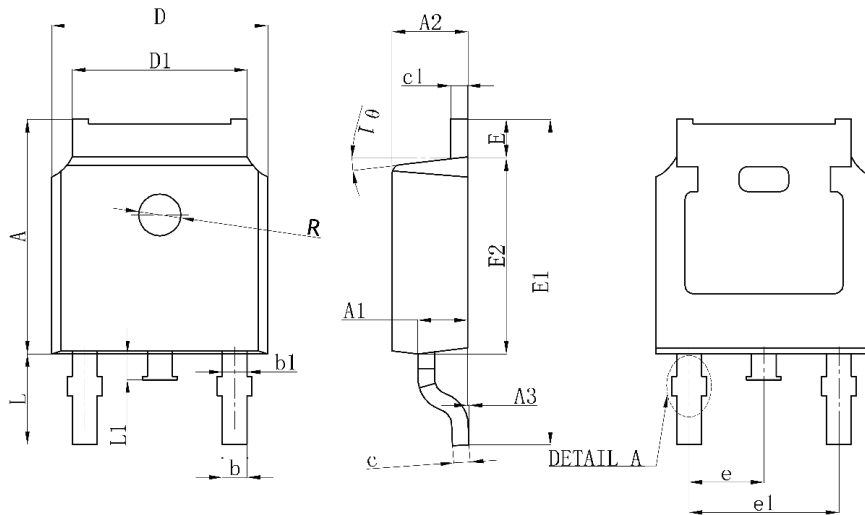

$0 \leq T, T' \leq 0.12$   
DETAIL A

Symbol	Dimensions In Millimeters		Dimensions In Inches	
	Min.	Max.	Min.	Max.
A	7.050	7.150	0.278	0.281
A1	0.960	1.060	0.038	0.042
A2	2.250	2.350	0.089	0.093
A3	0.000	0.100	0.000	0.004
b	0.760REF		0.030REF	
b1	1.000REF		0.039REF	
c	0.508REF		0.020REF	
c1	0.508REF		0.020REF	
D	6.550	6.650	0.258	0.262
D1	5.220	5.420	0.206	0.213
E	0.950	1.050	0.037	0.041
E1	9.700	10.100	0.382	0.398
E2	6.050	6.150	0.238	0.242
e	2.286BSC		0.090BSC	
e1	4.572REF		0.180REF	
L	2.650	2.950	0.104	0.116
L1	0.700	0.900	0.028	0.035
$\theta$	7°REF		7°REF	
R	1.300REF		0.051REF	
R1	0.250REF		0.010REF	